

10.1" Rugged Tablet PC

M101BT

Product Features:

- 10.1" 1280x800 IPS LED Panel with P-Cap Touch
- Low-power system with Intel® BayTrail-M processor
- IP65 water and dust proof
- Built-in Smart Card Reader
- Built-in 2D/1D Barcode Reader (Optional)
- Dual Camera Design: 5MP main camera with LED flash / 2MP Webcam
- Expansion port for USB connection (Optional)
- Hot-Swappable Battery Design / Optional high capacity battery pack
- 1 user-definable function key
- With Optical Bonding for Sunlight Readability



CE FCC

Product Specifications:

System Specification	Processor	Intel Celeron Quad-Core N2930 1.83GHz
	System Memory	4GB SODIMM DDR3L-1600 (up to 8GB)
	Storage	64GB mSATA MLC SSD (up to 256GB)
	Operating System	Windows 10 IoT Enterprise / Windows Embedded 8.1 Industry Pro / Windows 7 Pro for Embedded Systems
Display Specification	Size / Technology	10.1
	Resolution	1280x800 WUXGA
	Brightness	350 nits typ. With Optical Bonding for Sunlight Readability
	Touch	Multi-Touch Projective Capacitive
Wireless Communication	Contrast Ratio	800:1
	WLAN	802.11 a/b/g/n
	Bluetooth	Bluetooth 4.0 + Class I
	GPS	u-Blox Neo-6Q
System I/O Buttons Indicators Sensors Security	WWAN	Optional 4G (LTE, HSPA+, GSM/GPRS/EDGE, EV-DO Rev A, 1xRTT) or optional 3G (HSPA+, GSM/GPRS/EDGE)
	Audio	1 x Built-in Mic, 2 x 1W Speaker
	External I/O	1 x USB3.0, 1 x Audio Combo Conn. (Mic in / Line Out), 1 x Power Jack, 1 x Micro SD Slot, 1 x Micro SIM Slot
	Buttons	1 x Power, 1 x Home, 1 x Programmable Function Key
	LED Indicators	Power, Battery, HDD, RF
	Sensors	Light sensor, G sensor, Gyrometer, E-compass
	Security	Password security for user and hard disk lock Kensington lock slot Trusted platform module (TPM) V1.2
Data Capture	Mobile Device Management	SOTI MobiControl compatible
	Camera	5MP Auto-Focus Camera with LED Flash at rear / 2MP Camera at front side
	Barcode	Short range 1D/2D Barcode Reader (optional)
	Smart Card Reader	Comply with ISO7816-1.2.3 T=1 and T=0 protocol
Mechanical and Environment	Dimension (W x L x H)	271.8 x 197.2 x 19 mm (10.7 x 7.76 x 0.75 inches)
	Weight	1.2 kg (2.7 lbs) with standard battery, 1.4 kg (3.1 lbs) with optional high capacity battery
	Operating Temperature	-20°C to 60°C (AC mode), -10°C to 50°C (Battery mode)
	Storage Temperature	-30°C to 70°C (-22°F to 158°F)
	Humidity	10 to 90% RH, non-condensing
	IP Proof	IP65
	Shock	MIL-STD-810G Method 516.6 Procedure I
	Vibration	MIL-STD-810G Method 514.6 Procedure I
Power Management	Drop	MIL-STD-810G Method 516.6, 4 ft to concrete*
	Certifications	CE, FCC, IC
	Power Input	12-19V DC
	Battery	7.4V, typ. 5140 mAh Li-Polymer Battery (2S1P) 7.4V, typ. 10280 mAh Li-Polymer Battery (2S2P, optional)
	Battery Operating Time	7 hours **
	Adapter	100-240V, 50-60Hz / 19V DC

Dimensions :

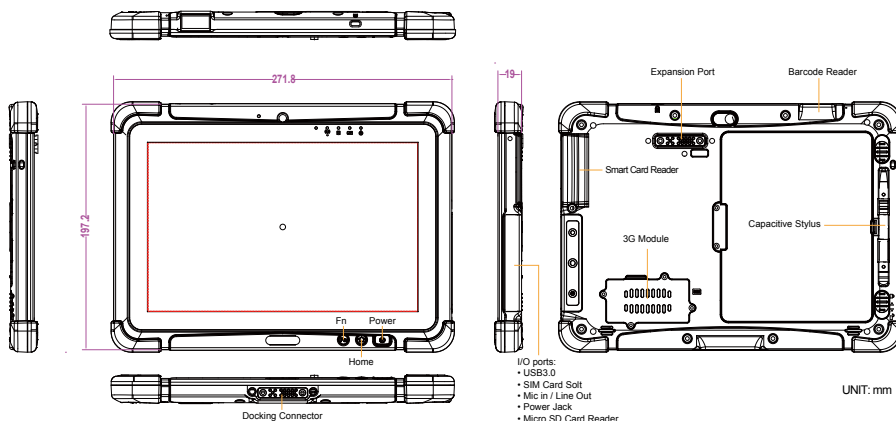

- * Note: The drop test with high-capacity battery must come with hand strap.
- ** Note: Measured at dimming LCD brightness. Varies depending on the usage conditions, or when an external device is attached.
- *** Note: this is a simplified drawing and some components are not marked in detail.
- **** Please contact our sales representative if you need further product information.
- ***** Note: All Specifications are subject to change without prior notice.

Accessories:

1. 19V 65W Power Adapter x 1
2. Power Cord x 1
3. Standard Battery x 1
4. Quick Start Guide x 1
5. Manual & Driver CD x 1
6. Capacitive Stylus x 1

Order Information:

M101BT	Basic
M101BT-3	3G
M101BT-LE	4G/LTE for Europe
M101BT-LA	4G/LTE for North America
M101BT-AP	With Active Pen