

電氣規格書



Released Date:2020/01/06-03:18:00



全漢企業股份有限公司
FSP TECHNOLOGY INC.

台灣 桃園市建國東路 22 號
NO.22, Jianguo E, Rd., Taoyuan city, Taiwan, R.O.C.
TEL:+886-3-375-9888 FAX:+886-3-375-6966

SPECIFICATION

FSP350-50TAC

9PA350D301

Main Feature: TFX 12V
Meet 2013 ErP
Meet Inlet 1.41
Active PFC Circuit
Meet Eff. 82%-85%-82%
+3.3 & +5V convert from +12V output
through DC to DC Design

JAN. 06, 2020

Rev: 1.00



全漢企業股份有限公司
FSP TECHNOLOGY INC.

MODEL: FSP350-50TAC

Revision History

<u>Rev</u>	<u>Description</u>	<u>Date</u>	<u>Author</u>
1.00	Original	2020/01/06	Aaron

1. GENERAL DESCRIPTION AND SCOPE

This is the specification of Model FSP350-50TAC AC-line powered switching power supply with active PFC (Power Factor Correction) circuit, meet EN61000-3-2 features.

The specification below is intended to describe as detailed as possible the functions and

performance of the subject power supply. Any comment or additional requirements to this specification from our customers will be highly appreciated and treated as a new target for us to approach.

2. REFERENCE DOCUMENTS

The subject power supply will meet the EMI requirements and obtain main safety approvals as following:

2.1. EMI REGULATORY

@EMC

2.2. SAFETY

@FCC

@CB_60950,62368

@UL_62368

@TUV_62368

3. INPUT ELECTRICAL SPECIFICATIONS

3.1. AC INPUT

Parameter	Min.	Nom. ⁽¹⁾	Max.	Unit
V _{in} (115Vac)	90	115	135	VAC _{rms}
V _{in} (230Vac)	180	230	265	VAC _{rms}

V _{in} Frequency	47	--	63	HZ
---------------------------	----	----	----	----

◆ Nominal voltages for test purposes are considered to be within $\pm 1.0V$ of nominal.

3.2. INRUSH CURRENT

Maximum inrush current from power-on (with power on at any point on the AC sine) and including, but not limited to, three line cycles, shall be limited to a level below the surge rating of the input line cord, AC switch if present, bridge rectifier, fuse, and EMI filter components. Repetitive ON/OFF cycling of the AC input voltage should not damage the power supply or cause the input fuse to blow.

3.3. INPUT LINE CURRENT & POWER FACTOR (P.F.)

(At Full load)

AC input	Input line current	P.F.@ Full Load
115V	< 4.0Amps – rms	> 0.95
230V	< 2.0Amps – rms	> 0.95

3.4. AC-DC power supplies shall not perform at less than:

(AC input=230V)

1. Power factor 0.8 at 20% of rated output.
2. Power factor 0.9 at 50% of rated output.
3. Power factor 0.95 at 100% of rated output.

3.5. EFFICIENCY

Under the load conditions defined in table 1. And table 2&table 3. And table 4.

The loading condition for testing efficiency shown in Table 1 represents a fully loaded system.

A ~ 50% (typical) loaded system and a ~ 20% (light) loaded system.

The loading condition for testing 12W efficiency shown in Table 3 meets Intel 1.41.

Table1. Loading Table for Efficiency Measurements

350W(loading shown in Amps)					
Load	+3.3V	+5V	+12V	-12V	+5Vsb
Light	1.59	1.59	4.53	0.05	0.39

Typical	3.97	3.97	11.32	0.12	0.97
Full	7.95	7.95	22.63	0.23	1.94

Table2. Minimum Efficiency & Load

Load	Voltage	Light	Typical	Full
Required Minimum Efficiency	115V	82%	85%	82%
	230V			

Table3. Loading Table for Efficiency Measurements

	12W(loading shown in Amps)					
Load	+3.3V	+5V	+12V1	+12V2	-12V	+5Vsb
12W	0.31	0.79	0.34	0.23	0	0.1

Table4. Minimum Efficiency & Load

Load	Voltage	12W
Required Minimum Efficiency	115V	60%

3.6 Standby Power Consumption (+5Vsb):

Efficiency > 45% @ 5Vsb/45mA & 115/230Vac input (2013 Lot 6)

Efficiency > 45% @ 5Vsb/90mA & 115/230Vac input (2010 Lot 6)

Efficiency > 75% @ 5Vsb/0.55A & 115/230Vac input (ASM and ErP* Lot 3 2014)

Efficiency > 75% @ 5Vsb/1A & 115/230Vac input (Recommend)

Efficiency > 75% @ 5Vsb/1.5A & 115/230Vac input (ASM and ErP Lot 3 2014)

Efficiency > 75% @ 5Vsb/2.5A & 115/230Vac input (Recommend)

4. OUTPUT ELECTRICAL REQUIREMENTS**4.1. OUTPUT VOLTAGE AND CURRENT RATING**

Output	MINIMUM LOAD	NORMAL LOAD	MAXIMUM LOAD	PEAK LOAD	LOAD REG.	LINE REG.	Ripple & Noise
+3.3V	0A	8A	16A		±5%	±1%	50mV P-P
+5V	0A	8A	16A		±5%	±1%	50mV P-P
+12V	0.1A	14.6A	29.18A		±5%	±1%	120mV P-P
-12V	0A	0.15A	0.3A		±10%	±1%	120mV P-P
+5Vsb	0.1A	1.25A	2.5A	3A	±5%	±1%	50mV P-P

(1) +3.3V & +5V total output not exceed 85W.

(2) Maximum combined current for the +12V outputs shall be 29.16A.

Voltages and ripple are measured at the load side of mating connectors with a 0.1uF monolithic ceramic capacitor paralleled by a 10uF electrolytic capacitor across the measuring terminals.

4.2. LOAD CAPACITY SPECIFICATIONS

The cross regulation defined as follows, the voltage regulation limits DC include DC Output ripple & noise.

LOAD	+3.3V	+5V	+12V	-12V	+5Vsb
Condition_1	X	X	X	X	2.5A
Condition_2	0A	0A	0.1A	0A	0.1A
Condition_3	0A	0A	1A	0.3A	0.1A
Condition_4	16A	6.44A	20.74A	0.3A	2.5A
Condition_5	1.67A	16A	20.74A	0.3A	2.5A
Condition_6	0A	0A	29.18A	0.1A	0.1A

4.3. OVER VOLTAGE PROTECTION

Voltage Source	Over Voltage Protection Point
+3.3V	3.76V-4.8V
+5V	5.75V-7.0V
+12V	13.5V-16.5V

4.4. SHORT CIRCUIT PROTECTION

Output short circuit is defined to be a short circuit load of less than 0.1 ohm.

In the event of an output short circuit condition on +3.3V, +5V, +12V or -12V output, the power supply will shut down and latch off without damage to the power supply. The power supply shall return to normal operation after the short circuit has been removed and the power switch has been turned off for no more than 2 seconds.

4.5. OVER CURRENT PROTECTION

Test: minimum load

OUTPUT VOLTAGE	Over current limit
+3.3V	18A~30A
+5V	18A~30A
+12V	32A~42A

4.6. OVER POWER PROTECTION

The power supply shall be shut down and latch off, when the output wattage of the power supply is higher from 420W to 525W.

4.7. POWER SIGNAL

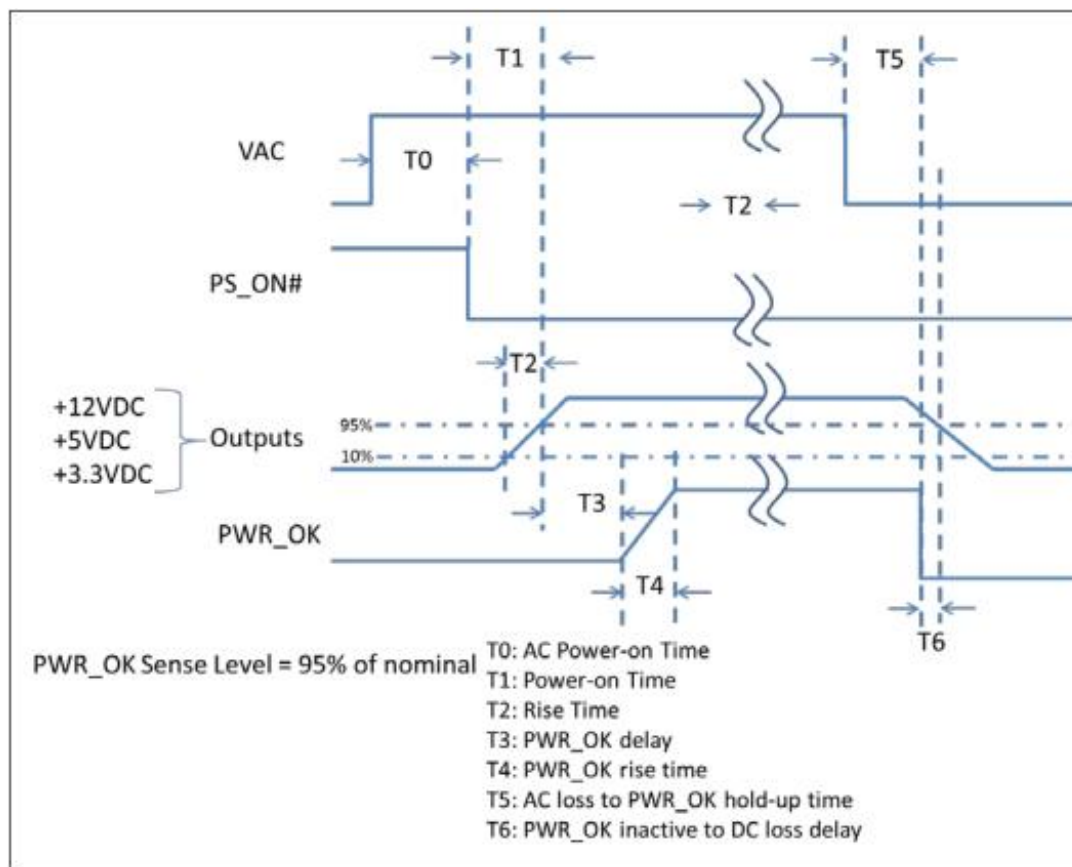

Parameter	Description	Value		
		Required	Recommended for non-alternative sleep mode	Recommended for alternative sleep mode
T0	AC power on time	<2s	-	-
T1	Power-on time	< 500ms	< 200ms	<150ms
T2	Rise time	0.2 – 20 ms	-	-
T3	PWR_OK delay	100* – 500 ms	100ms* – 250 ms	100ms* – 150ms
T4	PWR_OK rise time	< 10 ms	-	-
T5	AC loss to PWR_OK hold-up time	> 16 ms	-	-
T6	PWR_OK inactive to DC loss delay	> 1 ms	-	-

The output voltage will remain within specification, in the event that the input power is removed or interrupted, for the duration of one cycle of the input frequency. The interruption may occur at any point in the AC voltage cycle. The power good signal shall remain high during this test.

OUTPUT RISE TIME

(10% TO 95% OF FINAL OUTPUT VALUE @ Full load of Table 1)

115V-rms or 230V-rms: +12V&+5V&+3.3V&-12V&+5Vsb: 20ms Maximum

4.8. HOLD-UP TIME (80% Full load)

115V / 60Hz : 17 mSec. Minimum. ; 230V / 50Hz : 17 mSec. Minimum.

The output voltage will remain within specification, in the event that the input power is removed or interrupted, for the duration of one cycle of the input frequency. The interruption may occur at any point in the AC voltage cycle. The power good signal shall remain high during this test.

4.9. Dynamic

LOAD	+3.3V	+5V	+12V	-12V	+5Vsb
+3.3V	11.2A~16A	6.44A	20.74A	0.3A	2.5A
+5V	1.67A	11.2A~16A	20.74A	0.3A	2.5A
+12V	0A	0A	17.5~29.17A	0.1A	0.1A
Capacitive Load	3300uF	3300uF	3300uF	330uF	3300uF

5. FAN NOISE REQUIREMENTS

5.1. The subject power supply is cooled by a self-contained, 80mm, 12VDC fan.

5.2. FAN NOISE

AC INPUT	Full load	Typical load	Light load
115V	Noise < 45dB	Noise < 25dB	Noise < 25dB
230V			

6. ENVIRONMENTAL REQUIREMENTS

The power supply will be compliant with each item in this specification for the following environmental conditions.

6.1. TEMPERATURE RANGE

Operating	+0 to +40 deg. C
Storage	-20 to +70 deg. C

6.2. HUMIDITY

Operating	5 –95% RH, Non-condensing
Storage	5 –95% RH, Non-condensing

6.3. VIBRATION

Random Vibration

0.01g²/ Hz at 5 Hz, sloping to 0.02g²/ Hz at 20 Hz, and maintaining 0.02g²/ Hz from 20Hz to 500Hz. The area under the PSD curve is 3.13g RMS.

The duration shall be 20 minutes per axis for all three axes on all samples.

7. SAFETY TESTING

7.1. GROUND LEAKAGE CURRENT

The power supply ground leakage current shall be less than 3.5 mA.

7.2. DIELECTRIC STRENGTH

Primary to Frame Ground : 1800Vac for 3 sec.

Primary to Secondary : 1800Vac for 3 sec

7.3. INSULATION RESISTANCE

Primary to Frame Ground : 20M ohm , Minimum

Primary to Secondary : 20M ohm , Minimum

8. RELIABILITY

8.1. RELIABILITY

The power supply reliability, When calculated by MIL-HDBK-217;latest revision, are exceed 100,000 hours with all output at maximum load and an ambient temperature of 25°C .

9. LABELLING

Label marking will be permanent, legible and complied with all agency requirements.

9.1. MODEL NUMBER LABEL

Labels will be affixed to the sides of the power supply showing the following:

- Manufacturer's name and logo.
- Model no., serial no., revision level, location of manufacturer.
- The total power output and the maximum load for each output.
- AC input rating.

10. MECHANICAL SPECIFICATIONS

The mechanical drawing of the subject power supply, which indicate the form factor, location of The mounting holes, location, the length of the connectors, and other physical specifications of the subject power supply. Please refer to the attachment drawing.