

Description

The Smarter connected electronic thermostat, together with the dedicated Thermostat App, is a device which allows you to adjust and monitor the temperature in the rooms locally or remotely. The temperature level can be set locally for manual operation and the Boost mode can be activated. The Boost forces the switching on of the system for a limited time (30, 60 or 90 minutes) independent of the measured and programmed temperature. It can also display the temperature and humidity measured.

Thanks to its Wi-Fi connection, all the programming and most of the functions are performed simply and intuitively using the App in the home or remotely.

Smarter can be installed both in 503E flush-mounted boxes and in round flush-mounted boxes:

- type 500
- type 502PB (only for X8000/SX8000);
- type 0 800 21 (only for 0 490 36).

Technical data

Power supply	110 – 240 Vac, 50/60Hz
Absorption	2 W max
Maximum cable section	1 x 1.5mm ²
Operating temperature	5 – 40 °C
Temperature set-point	5 – 40 °C; increase of 0.5 °C
Type of activation	1BU
Pollution level	2
Rated pulse voltage	4 kV

Wireless device in compliance with 802.11b/g/n standard, frequency 2.4 – 2.4835 GHz, transmission power < 20 dBm. WPA/WPA2 safety protocol.

Dimensional data

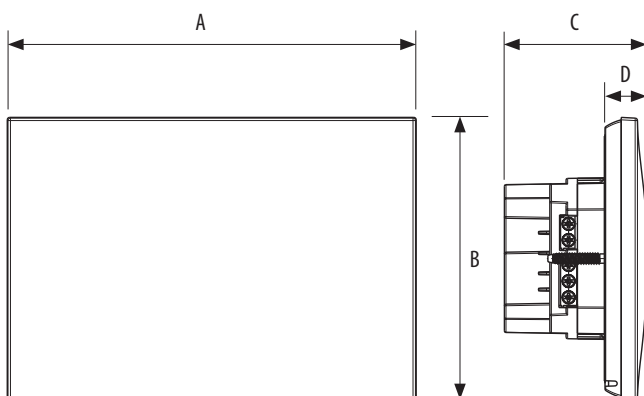

A	B	C	D
126 mm	87 mm	43,6 mm	12,6 mm

Front view

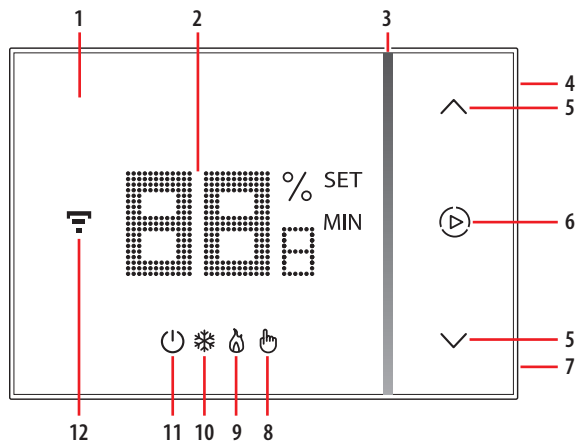

Rear view

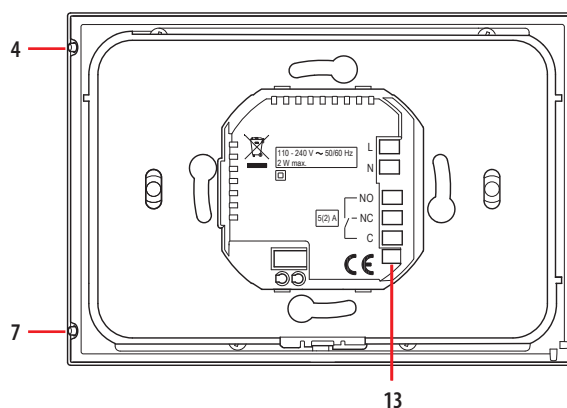

Legend

1. Touch screen display
2. Temperature/humidity display
3. “Boost” mode indicator
4. Wi-Fi connection key
5. Keys for temperature setting
6. Boost mode activation
7. Reset key (keep pressed for 10”, it restores the factory settings)
8. Manual mode indicator
9. ON heating indicator
10. ON cooling indicator
11. “OFF thermostat” indicator;
7 °C temperature (antifrost) in heating function;
35 °C temperature (heat protection) in cooling function.
12. Wi-Fi connection indicator
13. Connection clamps

Installation

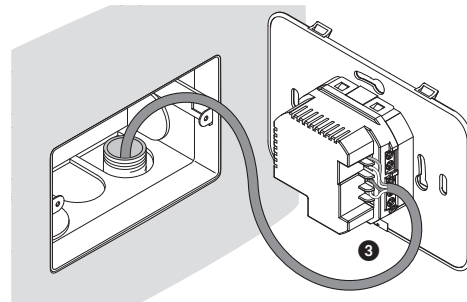
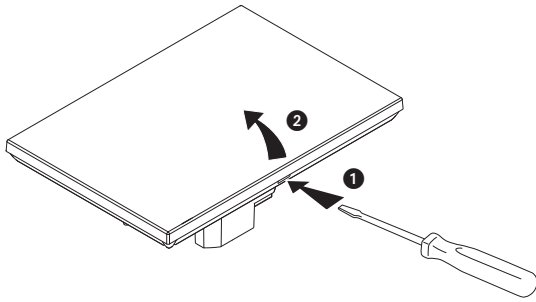

With 503E boxes - Screw centre distance 83.5 mm

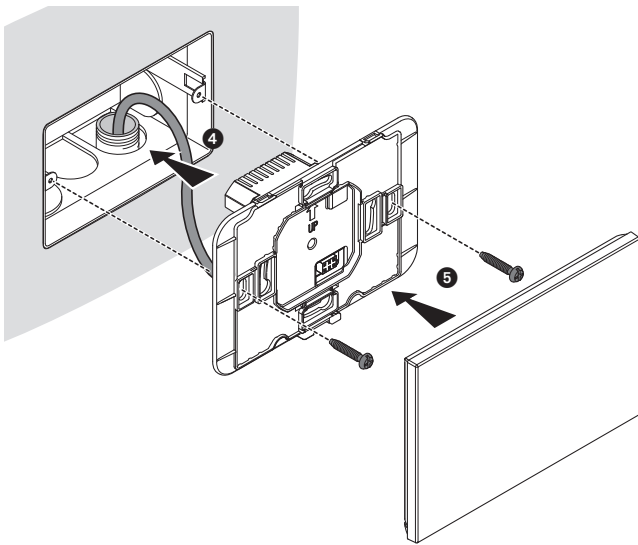

With 500 boxes

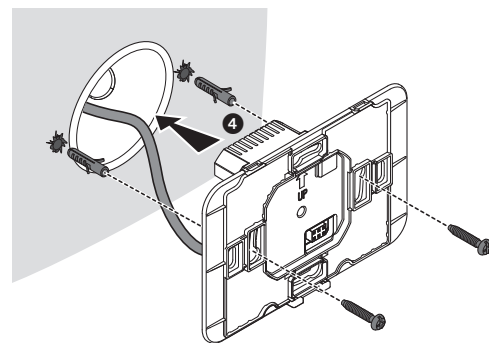

With 502 PB boxes (only for X8000/SX8000) - Screw centre distance 60 mm

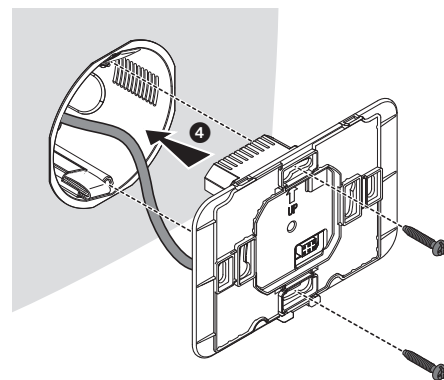

With 0 800 21 boxes (only for 0 490 36) - Screw centre distance 60 mm

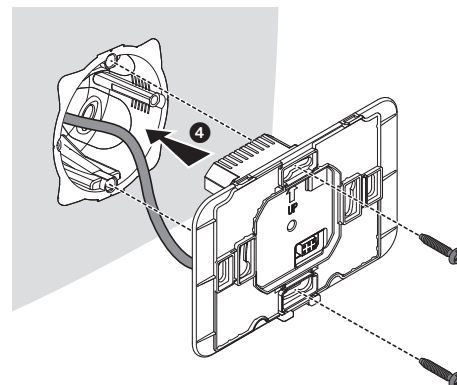

Caution: avoid tightening the screws too much, in order to prevent any base distortion that may compromise the correct installation of the device. The front must be tightly fixed to the base and the fastening clip should lock into place.

Once the installation has been done, wait for 2 hours before checking the read temperature.

Wiring diagrams

System only for heating with clean contact
(e.g. boiler agreement)

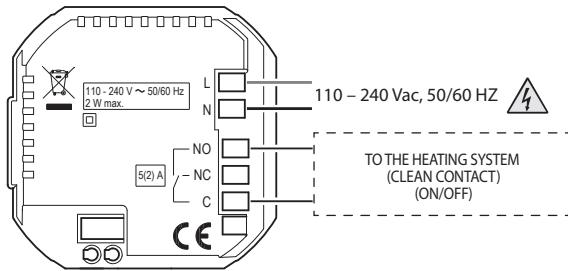

System only for heating with load to be controlled to the network voltage
(e.g. 230Vac solenoid valve)

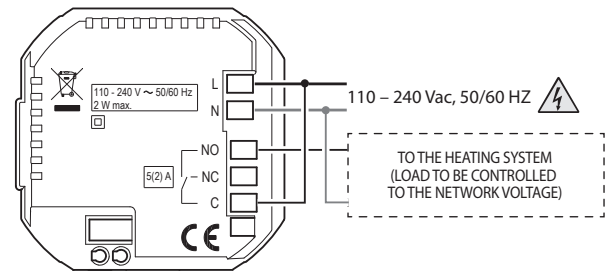

Heating and cooling* with floor system

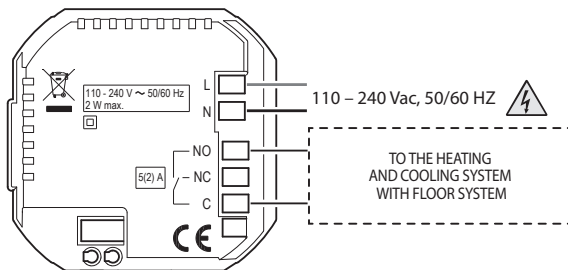

Heating and cooling* with different systems

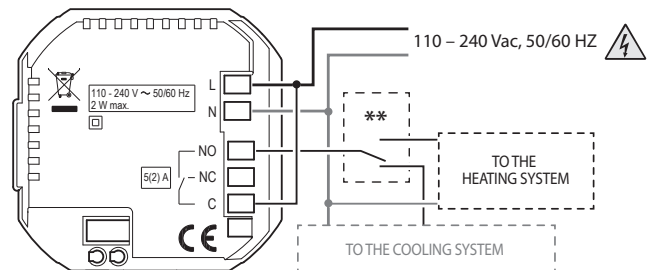

** External changeover switch must be properly switched when system function is changed from heating to cooling and vice versa.

! Switch the power supply OFF before any work on the system

*The cooling function can be activated only via App.

Thermostat App and technical documentation

Scan the QR code or look for "Thermostat" to download the Thermostat App in Apple Store or Google Play



Download all the technical documentation about Smarter

